



**STANDARD  
PRESSURE**

IDEAL FOR USE WITH  
**AUTO NOZZLE  
METER**

**GPI** > Fuel Transfer Pump

**M-1115**

Series

**12  
GPM**  
45 L/min

**115V  
AC**

**Stationary**

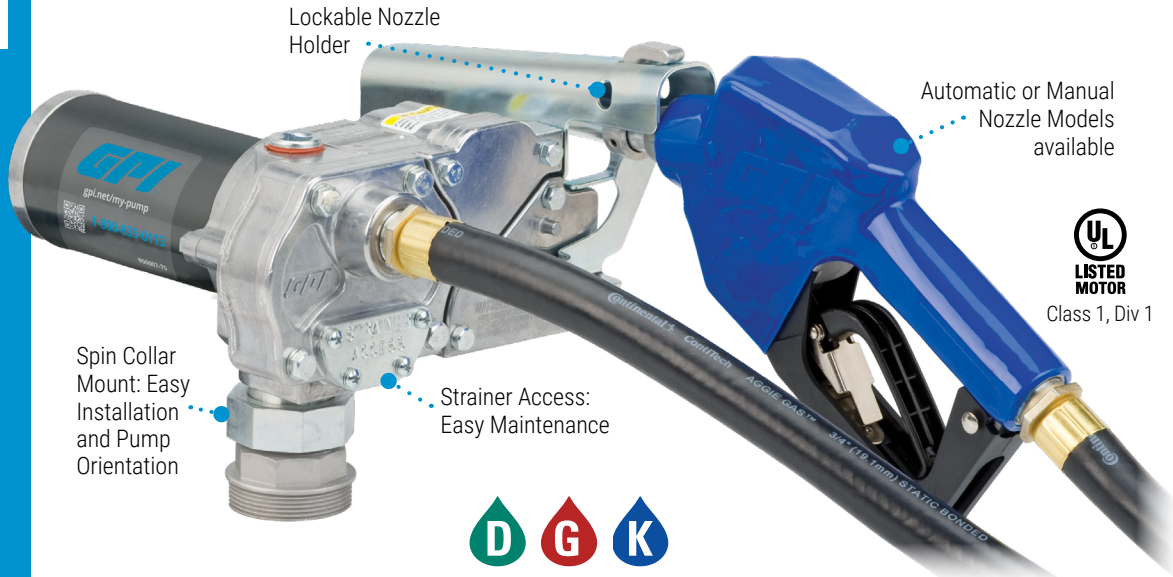

Class 1, Div 1



- Extremely long life and trouble-free operation
- Motor is explosion proof

**ELECTRICAL**

|               |  |
|---------------|--|
| Input:        | 115V (ac)  |
| Type:         | Rotary Gear  |
| Current Draw: | 1.8 amp  |
| Motor:        | 1400 RPM, 1/8 HP,<br>UL Listed to US and<br>Canadian Standards |

**PERFORMANCE**

|             |                            |
|-------------|----------------------------|
| Flow Rate:  | 12 GPM (45 L/min)          |
| Duty Cycle: | 30 min. ON,<br>30 min. OFF |

**OPERATING PRESSURE**

15 psi (1.03 bar) - Standard Pressure

**OPERATING TEMPERATURE**

-20°F to 125°F (-29°C to 52°C)

**PUMP HOUSING**

Corrosion-Resistant Diecast Aluminum

**MECHANICAL CONNECTIONS**

|                 |                         |
|-----------------|-------------------------|
| Inlet / Outlet: | 1 in. NPT / 3/4 in. NPT |
| Mounting:       | 2 in. NPT               |

**DISPENSING HOSE**

12 ft. (3.7 m) x 3/4 in.

**SUCTION PIPE**

Telescoping 15 to 40 in.  
(38.1 to 101.6 cm)

**WARRANTY**

2 Year Pump

**Install our tough M-1115 to your on-site fuel tanks for reliable fueling with minimal maintenance. The M-1115 will be by your side to keep your trucks on the road, your tractor working the fields, or your skid steer loader on the move until the job is finished.**

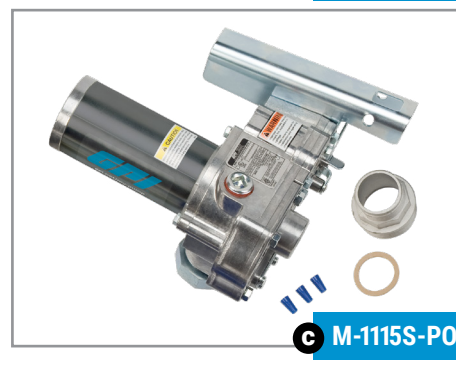

### > Ordering Information

|          | Part No.  | Model      | Nozzle    | Hose   | Mount       | Suction Pipe | Nozzle Holder |
|----------|-----------|------------|-----------|--------|-------------|--------------|---------------|
| <b>a</b> | 110000-82 | M-1115S-AU | Automatic | 12 ft. | Spin Collar | Included     | Lockable      |
| <b>b</b> | 110000-81 | M-1115S-MU | Manual    | 12 ft. | Spin Collar | Included     | Lockable      |
| <b>c</b> | 110000-87 | M-1115S-PO | None      | None   | Spin Collar | None         | Lockable      |

### > Compatible Fluids

*Designed, tested and approved for use with gasoline blends (up to E15), diesel fuel blends (up to B20) and kerosene.*

### > Pump Only Models

**Additional compatible fluids:** pump only models also support the use of aviation gasoline (AVGAS100LL) and kerosene grade (JET A).